

## TSK モジュールタイプ M-S H、M-S N シリーズ

### TSK Module-Type M-S H, M-S N Series



#### ▶ 構造 Construction :

TSK モジュールタイプ M - SH , M - SN シリーズの転動面は、軌道台、スライドユニットの片面に2列のサーキュラアーチ形状が精密加工されています。コンパクトなブロック内に組み込まれたリターンチューブによりボールがブロックとレールの間を無限循環運動をします。

The raceways of TSK module-type LMB guide series (M-SH,M-SN) are precisely processed into circular arch on the surface of the track and slide unit with two rows each in one side.

Steel balls perform the unlimited circulation between the rail and block through a return tube set in the block.

#### ▶ 特長 Features :

2組を並列に用い、スライドユニットの片面を押すだけで取付精度の調整が可能です。

2組を並列に用いることにより、4方向等定格荷重の仕様が可能です。

構造が単純化されている為、高速走行性能が優れています。

取付スペースの確保が難しい箇所に、HS型レールとの組み合わせが可能です。

When a pair of module-type LMB guides are used in parallel, the simple design permits easy mounting by adjusting each slide unit in contact with the rail track only by pushing one side of the unit.

By the use of a pair of units, the system is capable of withstanding loads in all directions.

The simple design enables high-speed travel.

Combination with HS-type rail is possible where securing enough mounting space is difficult.

#### ▶ 使用例 Example ;

精密LMBガイドHSシリーズの軌道台を利用した場合。

Mounting Example in Combination with HS-type Rail

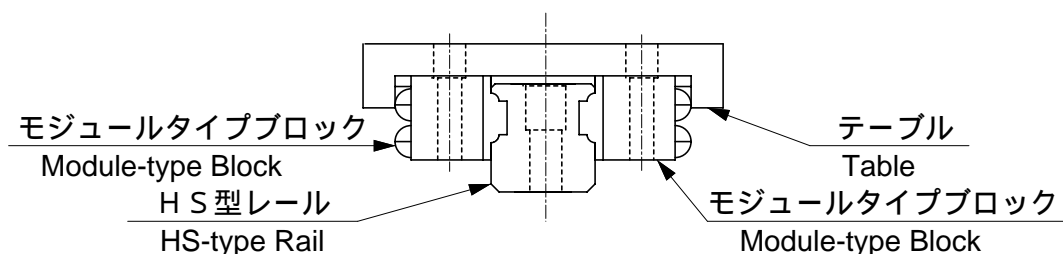

▶ 基本面の表示 Indication of Datum Plane

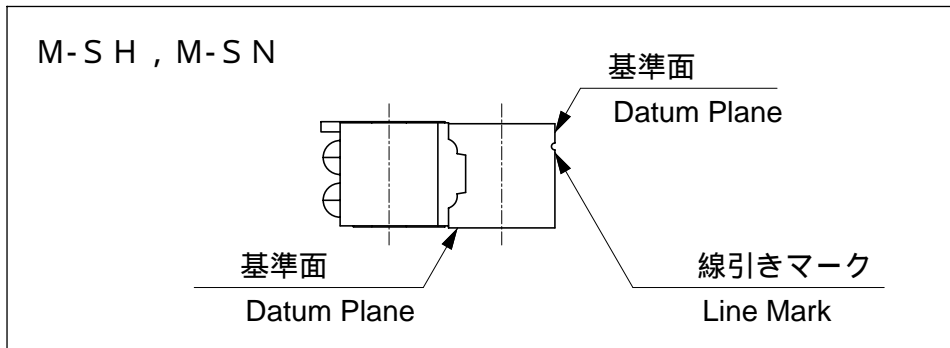

▶ レール標準長さ Standard Length of Track

型式 Model	M - S H					M - S N					
	15	25	35	40	45	10	15	25	35	40	45
Max.Length	1000	1500	3000	3000	3000	500	1000	1500	3000	3000	3000
標準長さ Standard Length	220	340	440	440	570	110	220	340	440	440	570
	340	640	840	840	1095	150	340	640	840	840	1095
	460	940	1240	1240	1620	230	460	940	1240	1240	1620
	640	1240	1640	1640	2140	310	640	1240	1640	1640	2140
	820		2040	2040	2670		820		2040	2040	2670
			2440	2440	2985				2440	2440	2985
		2840	2840					2840	2840		
		3000	3000					3000	3000		
F	60	60	80	80	105	40	60	60	80	80	105
E	20	20	20	20	22.5	15	20	20	20	20	22.5



呼び型番 Code Name

M 2 5 S H - B 1 - 6 4 0 - W 1

型式  
Model No.

軌道台全長 (mm)  
Length of Track (mm)

一軸に組み合わせるスライドユニット個数  
Number of Slide Units on the Track

同一平面上で使用する軸数  
Number of Tracks Used on the Same Plane

TSK モジュールタイプ M-S Hシリーズ (高予圧タイプ)

TSK Module-Type M-S H Series (High-preload Block)

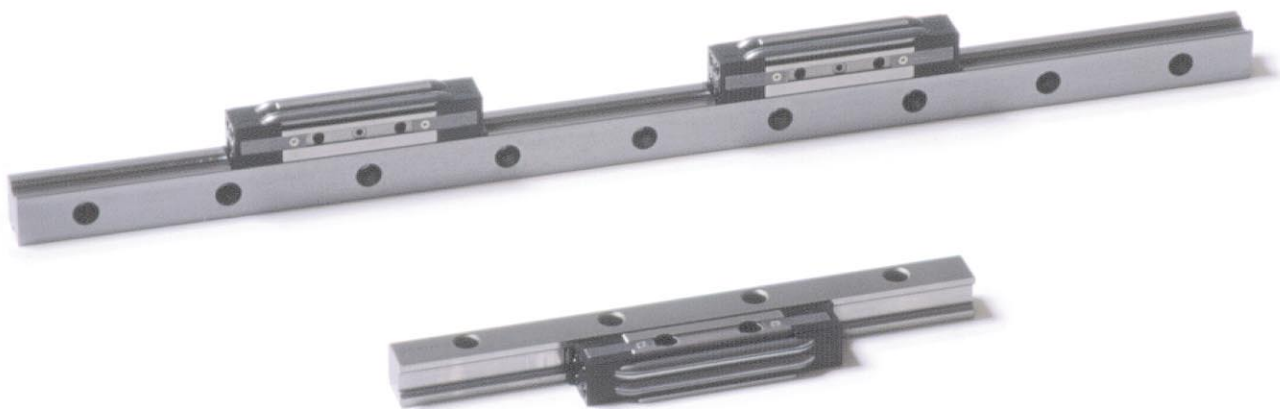

型式 Model No.	組込寸法 Mounting dimension		スライドユニット寸法 Slide unit dimension												
	H	W4	W1	W2	L1	L2	L3	H2	H3	H5	D1	h1	M1	S	d1
M15SH	15	30	16.6	10	81	44	20	14.5	3	5.8	6.5	3.5	M 4	3.3	2
M25SH	20	42	22.4	13	111	66	35	19.5	4	7.8	9.5	5.4	M 6	5.3	3
M35SH	25	55	29.1	16	141	83	45	24.5	5	9.8	11	6.5	M 8	6.8	3
M40SH	30	65	35	19	156	92	50	29.5	8	10.8	14	8.6	M10	8.6	4
M45SH	35	75	39.9	21.5	180	110	60	34.5	9	12.8	17.5	10.8	M12	10.5	4

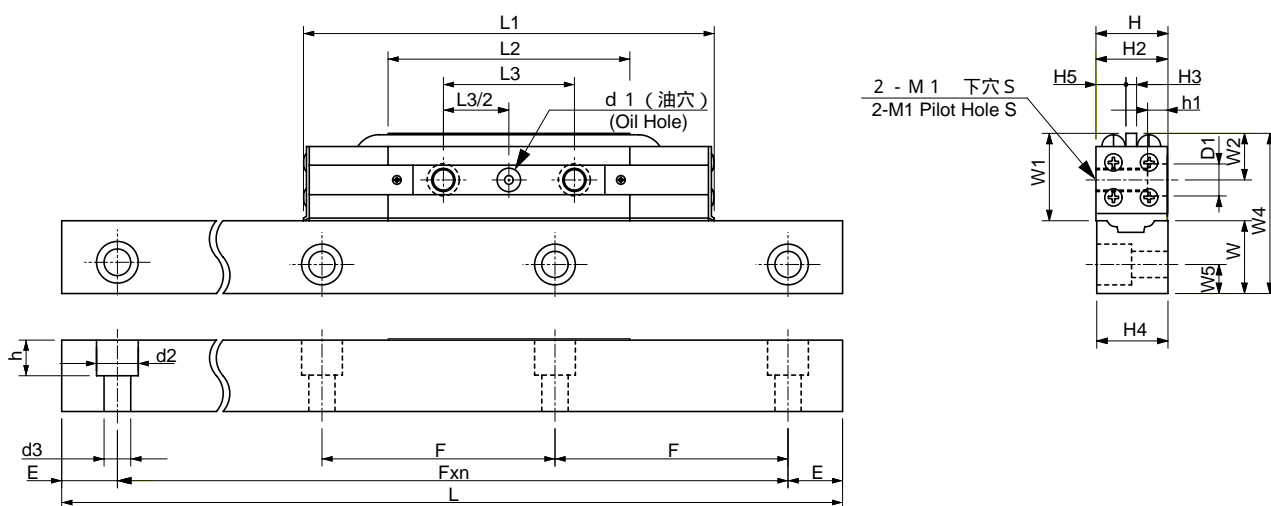

単位 mm

軌道台寸法 Rail track dimension								基本定格荷重 Basic rated load [N]		静定格トルク Rated static torque [ N · m ]		質量 Weight スライドユニット Slide Unit [kg]		軌道台 Track [kg/m]
W	W5	H4	d2	d3	h	E	F	C	Co	MA	MB			
13	6	14.5	6	3.4	5	20	60	4340	6670	40.9	40.9	0.07	1.3	
19	8	19.5	9.5	5.5	9	20	60	10310	15010	138	138	0.23	2.5	
25	10	24.5	14	9	12	20	80	19020	26680	327	327	0.46	4.1	
29	12	29.5	14	9	12	20	80	23060	30950	396	396	0.76	5.9	
34	14.5	34.5	17.5	11	16	22.5	105	30680	41690	639	639	1.1	8.1	

TSK モジュールタイプ M-S Nシリーズ (低予圧タイプ)

TSK Module-Type M-S N Series ( Low-preload Block )



型 式 Model No.	組込寸法 Mounting dimension		ス ラ イ ド ユ ニ ッ ト 寸 法 Slide unit dimension											
	H	W4	W1	W2	L1	L2	L3	H2	H3	D1	h1	M1	S	d1
M10SN	11	23	11.7	7	69	37	15	10.8	1.8	5	3	M 3	2.55	2
M15SN	15	30	16.6	10	81	44	20	14.5	2.2	6.5	3.5	M 4	3.3	2
M25SN	20	42	22.4	13	111	66	35	19.5	2.3	9.5	5.4	M 6	5.3	3
M35SN	25	55	29.1	16	141	83	45	24.5	2.4	11	6.5	M 8	6.8	3
M40SN	30	65	35	19	156	92	50	29.5	4.0	14	8.6	M10	8.6	4
M45SN	35	75	39.9	21.5	180	110	60	34.5	5.1	17.5	10.8	M12	10.5	4

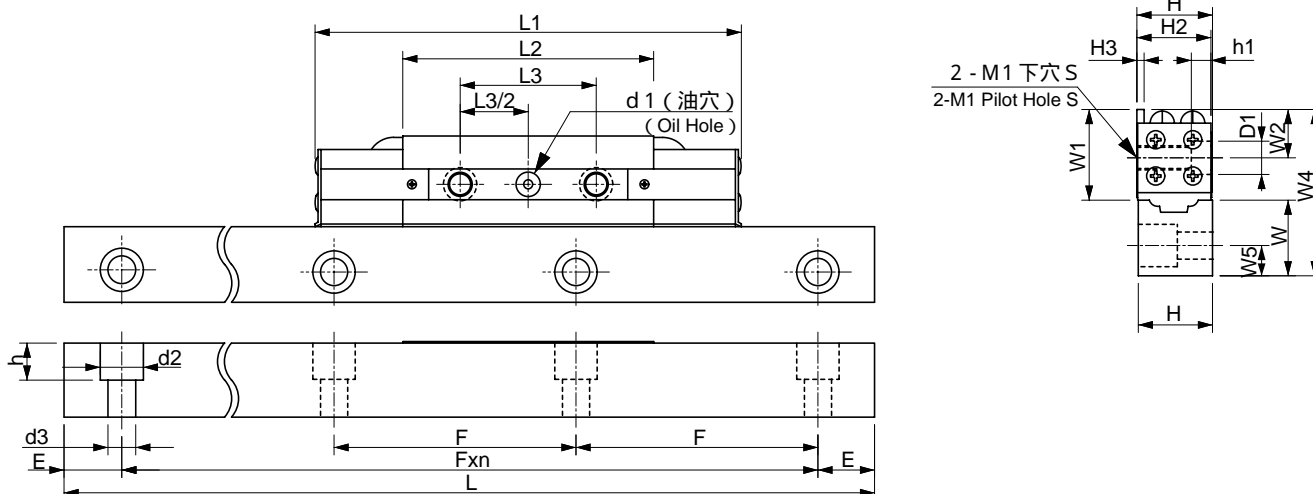

単位 mm

軌道台寸法 Rail track dimension								基本定格荷重 Basic rated load [ N ]		静定格トルク Rated static torque [ N · m ]		質量 Weight	
W	W5	H4	d2	d3	h	E	F	C	Co	M <sub>A</sub>	M <sub>B</sub>	スライド ユニット Slide Unit [kg]	軌道台 Track [kg/m]
11	5	10.8	6	3.4	5	15	40	2610	4370	23.1	23.1	0.04	0.82
13	6	14.5	6	3.4	5	20	60	4340	6670	40.9	40.9	0.07	1.3
19	8	19.5	9.5	5.5	9	20	60	10310	15010	138	138	0.23	2.5
25	10	24.5	14	9	12	20	80	19020	26680	327	327	0.46	4.1
29	12	29.5	14	9	12	20	80	23060	30950	396	396	0.76	5.9
34	14.5	34.5	17.5	11	16	22.5	105	30680	41690	639	639	1.1	8.1